

TA7205AP

5.8W AUDIO POWER AMPLIFIER

FOR CAR-STEREO, CAR-RADIO OUTPUT

- . Output Power:
 - $P_{OUT}=5.8W(\text{Typ.})$ at $V_{CC}=13.2V$, $R_L=4\Omega$, THD=10%
 - $P_{OUT}=9.2W(\text{Typ.})$ at $V_{CC}=13.2V$, $R_L=2\Omega$, THD=10%
- . Maximum Output Power:
 - $P_{OM}=9.5W(\text{Typ.})$ at $V_{CC}=13.2V$, $R_L=4\Omega$
- . Low Distortion:
 - THD=0.15% at $P_{OUT}=1W$, $G_V=55dB$
 - THD=0.07% at $P_{OUT}=1W$, $G_V=44dB$
- . Wide Operating Supply Voltage Range : $V_{CC}=9\sim 18V$
- . Low Noise.
- . Current Limiting for Short-Circuit Protection.
- . Built in Thermal Short-down Circuit.
- . Built in Surge Voltage Protection Circuit.

Unit in mm

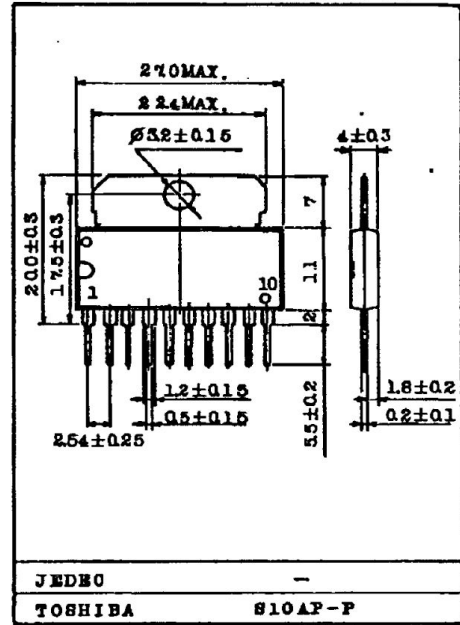

MAXIMUM RATINGS ($T_a=25^{\circ}C$)

CHARACTERISTIC	SYMBOL	RATING	UNIT
Operating Supply Voltage	V_{CC}	18	V
Quiescent Supply Voltage	V_{CCQ}	25	V
Output Current (Peak)	$I_O(\text{peak})$	4.5	A
Power Dissipation	P_D	7.5	W
Operating Temperature	T_{opr}	-20 ~ 75	$^{\circ}C$
Storage Temperature	T_{stg}	-55 ~ 150	$^{\circ}C$

(Minimum Operating Voltage is 9V)

TA7205AP

T-74-05-01

ELECTRICAL CHARACTERISTICS

(Unless otherwise specified $V_{CC}=12.5V$, $R_L=4\Omega$, $R_g=600\Omega$, $R_f=82\Omega$, $f=1kHz$, $T_a=25^\circ C$)

CHARACTERISTIC	SYMBOL	TEST CIR-CUIT	TEST CONDITION	MIN.	TYP.	MAX.	UNIT
Quiescent Current	I _{CCQ}	-	-	-	-	60	mA
			$V_{CC}=18V$	-	-	80	
Output Power	P _{OUT}	-	THD=10%	4.5	5	-	W
			$V_{CC}=13.2V$, THD=10%	-	5.8	-	
			$V_{CC}=13.2V$, $R_L=2\Omega$, THD=10%	-	9.2	-	
Maximum Output Power	P _{OM}	-	$V_{CC}=13.2V$	-	9.5	-	W
Total Harmonic Distortion	THD	-	P _{OUT} =1W	-	0.15	1.0	%
			P _{OUT} =100mW	-	0.2	1.0	
			P _{OUT} =1W, $R_L=2\Omega$	-	0.25	1.0	
Voltage Gain (Note)	G _V	-	$V_{IN}=2.45mV_{rms}$	52	55	58	dB
Input Resistance	R _{IN}	-	$V_{OUT}=2V_{rms}$	30	40	-	k Ω
Output Noise Voltage	V _{NO}	-	$R_g=10k\Omega$, BW=50 ~ 20kHz	-	-	3.5	mV

Note: In regard to the value of voltage gain (closed loop), it is possible to be classified.

TA7205AP

T-74-05-01

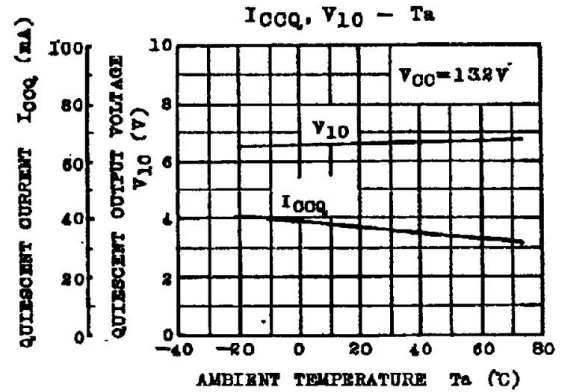
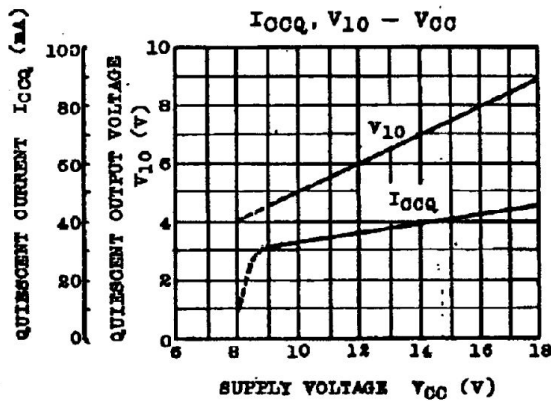
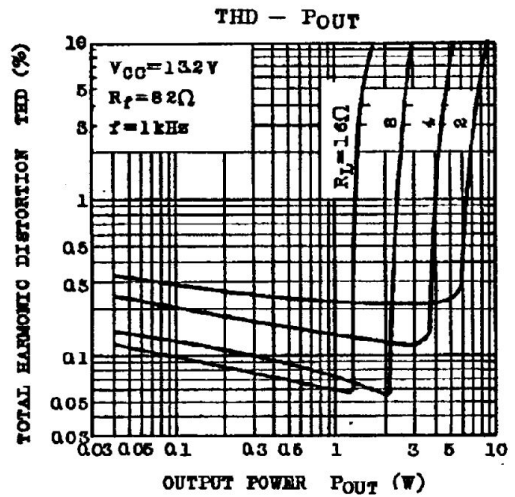
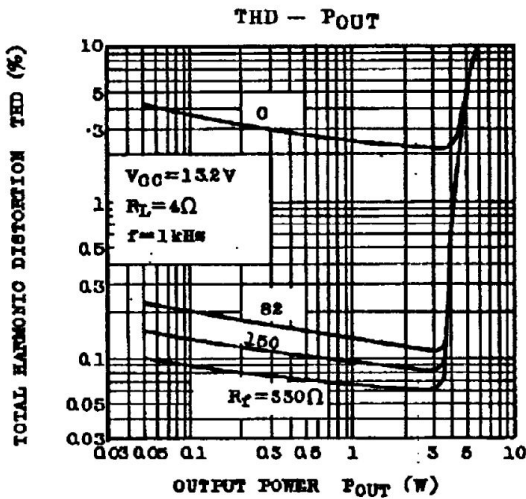
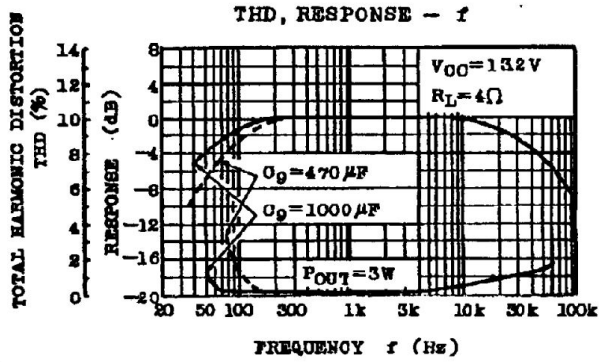
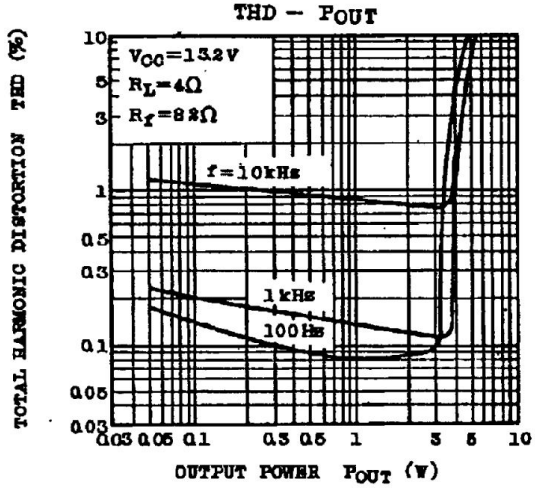

AUDIO LINEAR IC

TA7205AP

T-74-05-01

EQUIVALENT CIRCUIT

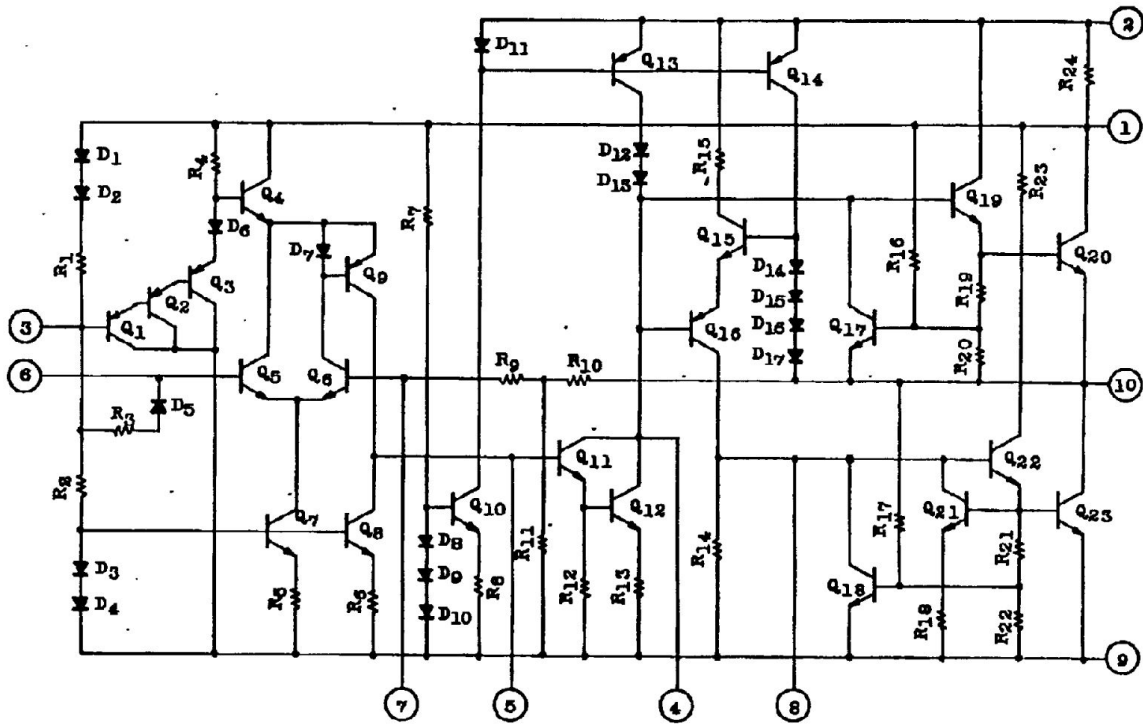

TEST AND APPLICATION CIRCUIT

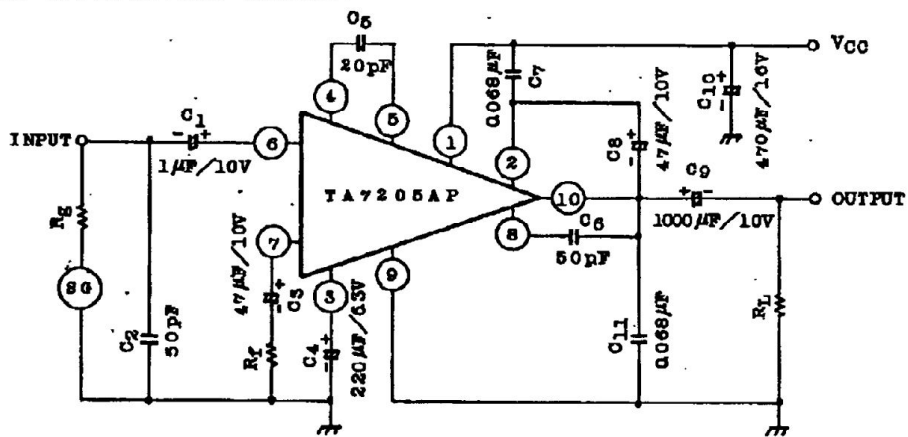

Note: Metal Tab must be connected to GND level or Non-connection.
C7 and C11 are polyester film capacitors.

TOSHIBA

TA7205AP

T-74-05-01

