



491460209 6V 7Ah(20hr)

The rechargeable batteries are lead-lead dioxide systems. The dilute sulfuric acid electrolyte is absorbed by separators and plates and thus immobilized. Should the battery be accidentally overcharged producing hydrogen and oxygen, special one-way valves allow the gases to escape thus avoiding excessive pressure build-up. Otherwise, the battery is completely sealed and is, therefore, maintenance-free, leak proof and usable in any position.



Battery Construction

Component	Positive plate	Negative plate	Container	Cover	Safety valve	Terminal	Separator	Electrolyte
Raw material	Lead dioxide	Lead	ABS	ABS	Rubber	Copper	Fiberglass	Sulfuric acid

General Features

- ☒ Absorbent Glass Mat (AGM) technology for efficient gas recombination of up to 99% and freedom from electrolyte maintenance or water adding.
- ☒ Not restricted for air transport-complies with IATA/ICAO Special Provision A67.
- ☒ UL-recognized component.
- ☒ Can be mounted in any orientation.
- ☒ Computer designed lead, calcium tin alloy grid for high power density.
- ☒ Long service life, float or cyclic applications.
- ☒ Maintenance-free operation.
- ☒ Low self discharge.
- ☒ Case and cover available in both standard and flame retardant ABS.

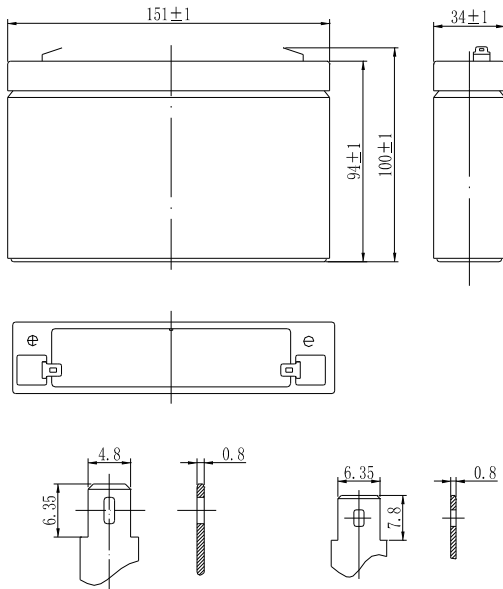

Performance Characteristics

Battery model	CP670			
Nominal voltage	6V			
Number of cell	3			
Capacity (25°C)	20hR (0.35A, 5.25V)	10hR (0.65A, 5.25V)	5hR (1.2A, 5.25V)	1hR (4.7A, 4.80V)
	7.0Ah	6.5Ah	6Ah	4.7Ah
Dimensions	Length	Width	Height	Total Height
	151±1mm	34±1mm	94±1mm	100±1mm
Approx. weight	1.2 Kg (2.6 lbs)			
Internal resistance	Full charged at 25°C: 14mOhms			
Self discharge	3% of capacity declined per month at 20°C (average)			
Operating temperature range	Discharge	Charge	Storage	
	-20~60°C	-10~60°C	-20~60°C	
Max. discharge current (25°C)	105A (5s)			
Short circuit current	350A			

Discharge Constant Current (Amperes at 77°F25°C)

End Point Volts/Cell	5min	10min	15min	30min	1h	3h	5h	10h	20h
1.60V	28.1	17.3	14.0	8.05	4.70	1.82	1.29	0.66	0.37
1.65V	26.4	16.8	13.7	7.85	4.65	1.79	1.26	0.66	0.37
1.70V	25.5	16.4	13.4	7.70	4.57	1.75	1.25	0.66	0.37
1.75V	23.7	15.9	13.1	7.45	4.46	1.70	1.20	0.65	0.36
1.80V	21.2	15.4	12.3	7.00	4.30	1.64	1.19	0.65	0.36

Discharge Constant Power (Watts at 77°F25°C)

End Point Volts/Cell	5min	10min	15min	30min	45min	1h	2h	3h	5h
1.60V	53.3	34.0	27.9	16.0	12.0	9.37	5.05	3.60	2.25
1.65V	51.6	33.3	27.4	15.6	11.9	9.28	5.00	3.56	2.23
1.70V	50.0	32.5	26.7	15.3	11.7	9.12	4.95	3.50	2.20
1.75V	46.5	31.4	26.0	14.8	11.4	8.86	4.90	3.38	2.17
1.80V	41.0	30.3	24.5	14.0	11.0	8.55	4.83	3.25	2.12

(Note)The above characteristics data are average values obtained within three charge/discharge cycles not the minimum values.

