

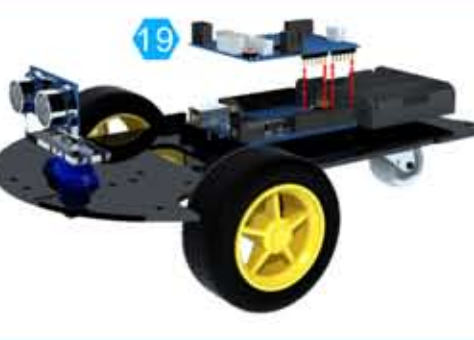

- | | | | |
|---|---|---|--|
| 1
M3*30 screws
4 bars | 3
M2*10 screws
2 bars | 5
M2 nuts
2 pieces | 7
Fastener
4 pieces |
| 2
M3*6 screws
8 bars | 4
M2 micro servo screws
3 bars | 6
M3 nuts
14 pieces | |
| 8
M3*6*4 screws
2 bars | 10
Ultrasonic bracket
1 piece | 11
Battery container
1 piece | 12
Wheel
2 pieces |
| 9
M3*6 socket screws
10 bars | 13
Hammer caster
1 piece | 14
Servo
1 piece | 15
Deceleration DC motor
2 pieces |
| 17
Chassis
1 piece | 18
Arduino board
1 piece | 19
Motor drive board
1 piece | 20
Ultrasonic module
1 piece |

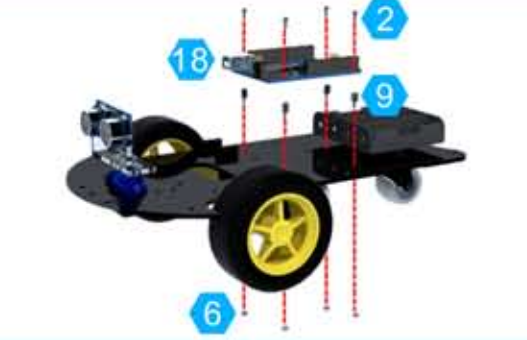

UCTRONICS®

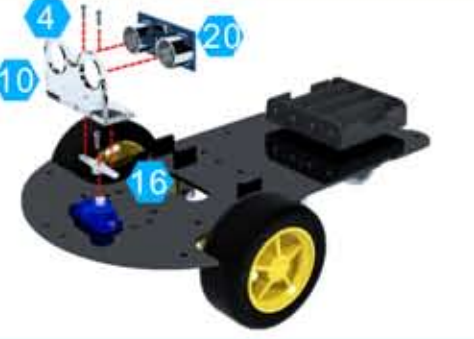
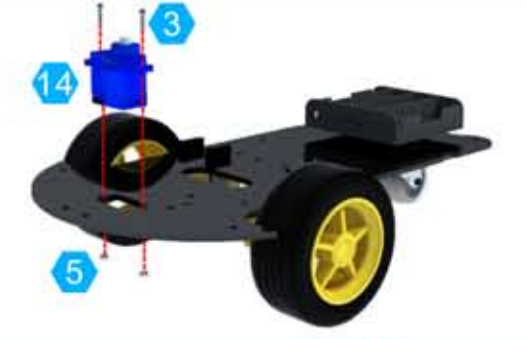
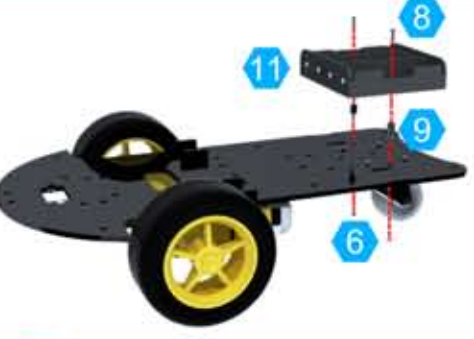
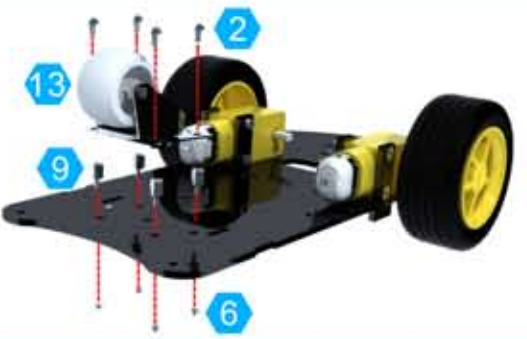
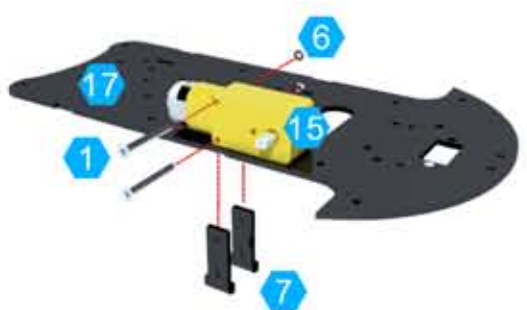